

**POLAIR**  
**F36A0100**

*Flynn Talbot*



**Description**

Pendant lamp with transparent borosilicate glass diffuser, sandblasted on the bottom. Black anodized aluminium structure.



**Dimensions**

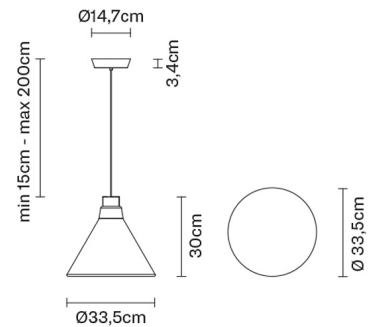

**Voltage**

220-240V

**Dimmable LED**

PUSH 1..10V

**Material**

Glass - Aluminium

**Light source and alternative bulbs**

LED 1x10W-40°  
3000K  
920lm Cri 80+

**Available diffuser colours**

Transparent

**Available structure colours**

Black

**Included accessories**

LED  
Dimmable electronic driver

**Weight Lamp**

Net: 2.42 kg

**Packaging**

Gross weight: 3.52 kg  
Volume: 0.075 m<sup>3</sup>  
Number of boxes: 1

**Specs**

**ERC** IP40