

# formosa

design aldo Cibic 2005

Collezione di lampade con diffusore in tessuto di forma asimmetrica, utilizzabile singolarmente o in aggregato, per lampade da terra, tavolo, sospensione.

Materiali. Tessuto bianco o rosso, metallo.

A collection of lamps with a asymmetrical texture shade, which can be used singularly or together with another element for floor, wall, table and suspension lamps. Materials: texture white or red, metal.

Kollektion von Lampen mit einem gewebten asymmetrischen Schirm (weiss oder rot), der als einzige Lampe oder zusammen mit einem anderen Beleuchtungselement zu benutzen ist.



# formosa

design aldo cibic 2005

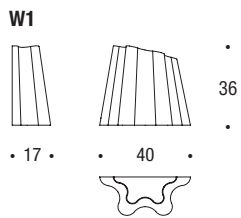

W1 1x E27 MAX 100W

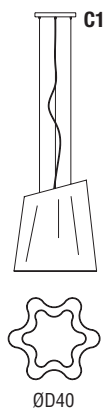

ØD40

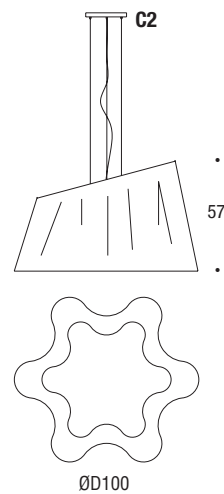

ØD100

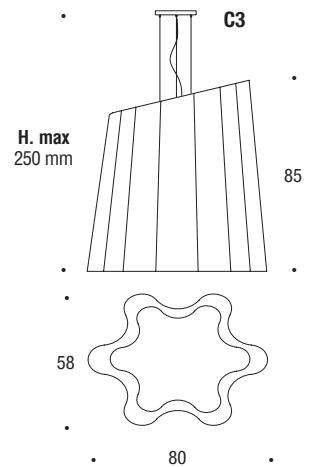

H. max  
250 mm

58

80

85

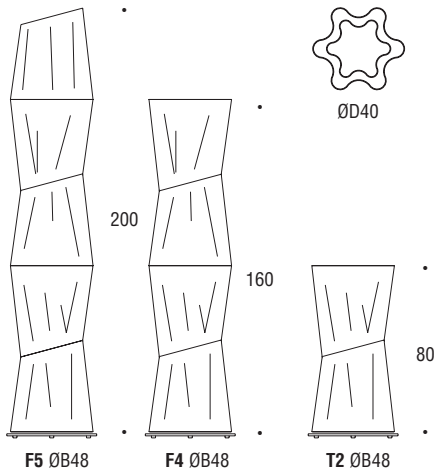

ØD40

200

160

80

F5 ØB48

F4 ØB48

T2 ØB48

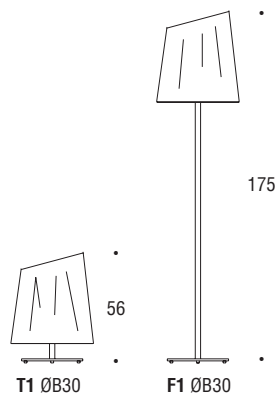

T1 ØB30

F1 ØB30

C1 1x E27 MAX 100W   
 C2 1x E27 MAX 150W   
 C3 1x E27 MAX 250W

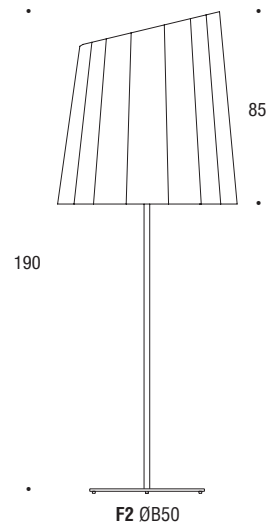

190

85

F2 ØB50

F5 10x  
 F4 8x E14 MAX 40W   
 T2 4x



F1/T1 2x E14 MAX 60W



F2 1x E27 100W + 2 E27 100W





# formosa

design aldo Cibic 2005







**formosa**  
design aldo cibic 2005



Marazzi, Sassuolo - Modena - Italia (Cibic e Partners)







# formosamaxi

design aldo cubic 2006





